

ORDER INFORMATION

DEVICE ¹⁾	PACKAGE	TOP MARKING ²⁾	ENVIRONMENTAL ³⁾
JW77156DESOP#TR	ESOP8	J77156D YW□□□□□	Green

Notes:

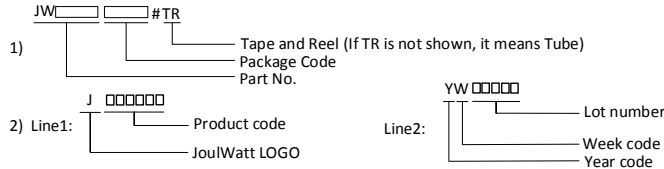

3) All JoulWatt products are packaged with Pb-free and Halogen-free materials and compliant to RoHS standards.

PIN CONFIGURATION

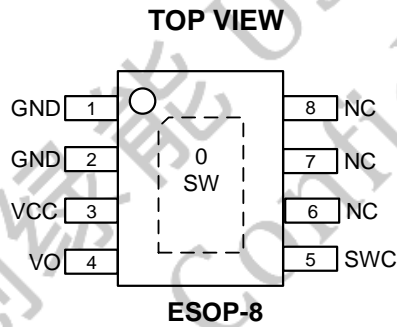

ABSOLUTE MAXIMUM RATING¹⁾

SW Pin	60V
SWC Pin	60V
VO Pin	28V
VCC Pin.....	6.5V
Junction Temperature ^{2) 3)}	150°C
Storage Temperature	-65°C to 150°C
Lead Temperature (Soldering, 10sec.)	260°C
Continuous Power Dissipation (TA = +25 °C) ⁴⁾ ESOP-8.....	2.5W

RECOMMENDED OPERATING CONDITIONS

SW Pin.....	4.7V to 48V
SWC Pin.....	4.7V to 48V
VO Pin.....	2.5V to 20V
VCC Pin.....	4.5V to 6.4V
Operation Junction Temperature	-40°C to 125°C

THERMAL PERFORMANCE⁵⁾

	θ_{JA}	θ_{Jc}
ESOP8.....	50	10°C/W

Note:

- 1) Exceeding these ratings may damage the device. These stress rating do not imply function operation of the device at any other conditions beyond those indicated under RECOMMENDED OPERATING CONDITIONS.
- 2) Continuous operation over the specified absolute maximum operating junction temperature may damage the device.
- 3) The device is not guaranteed to function outside of its operating conditions.
- 4) The maximum allowable continuous power dissipation at any ambient temperature is calculated by $P_D(MAX) = (T_J(MAX) - T_A) / \theta_{JA}$.
- 5) Measured on JESD51-7, 4-layer PCB.

For 和创绿能 Use Only
JoulWatt Confidential

ELECTRICAL CHARACTERISTICS

T_A = 25°C, unless otherwise stated

Advance Information, not production data, subject to change without notice.

Item	Symbol	Condition	Min.	Typ.	Max.	Units
<i>VCC Section</i>						
VCC Voltage	VCC	SW=40V, VCC=2.2uF		5.8		V
VCC Startup Voltage	V _{CC_Startup}			4.05		V
VCC UVLO	V _{CC_UVLO}			3.95		V
Quiescent Current	I _q	VCC=4.5V, VCC=2.2uF		24		uA
<i>Internal Driver Section</i>						
Internal Gate Pull up Current ⁶⁾	I _{GU}	GT=1V		0.65		A
Internal Gate Pull down Current ⁶⁾	I _{GD}	GT=5V		4.7		A
Internal Gate Minimum on Time ⁶⁾	T _{MIN_ON}			1.3		uS
Internal Gate Minimum off Time ⁶⁾	T _{MIN_OFF}			700		nS
Turn-on Total Delay ⁶⁾	T _{DON}			84		nS
Turn-off Total Delay ⁶⁾	T _{DOF}			22.4		nS
<i>SWC and VO Section</i>						
Internal MOSFET Turn on Threshold ⁶⁾	V _{SW_ON}			-300		mV
Internal MOSFET Turn off Threshold ⁶⁾	V _{SW_OFF}			-10		mV
Internal MOSFET Turn off Threshold in MOT ⁶⁾	V _{SW_OFF_MOT}			+150		mV
SW Control Voltage ⁶⁾	V _{SW_REG}			-40		mV
SW Control Voltage MAX ⁶⁾	V _{SW_REG_MAX}			-170		mV
VO Enable Charge Voltage	V _{O_EN}	VCC=4V, SW=0V		4.55		V
VO Disable Charge Voltage	V _{O_DIS}	VCC=4V, SW=0V		4.35		V
VCC Charge Current	I _{CV}	SW=40V, VCC=4V		44		mA
VO Charge Current	I _{VO_CHG}	SW=0V, VCC=4V, VO=5V		20		mA
Vo Short-circuit Detection Voltage	V _{O_SHORT}		1.8	2.1	2.3	V
<i>Internal MOSFET Section</i>						
Internal MOSFET Rdson ⁶⁾	R _{dson}			13		mΩ
Breakdown Voltage	B _{(BR)DSS}		60			V

6) Guaranteed by design. Not tested in production.

PIN DESCRIPTION

Pin No.	Name	Description
1,2	GND	Power Ground.
3	VCC	Power supply. Bypass a Capacitor Between VCC and GND.
4	VO	Output Voltage Sensing and Charging to VCC.
5	SWC	Internal Power MOSFET Drain Voltage Sensing. Charging to VCC.
6,7,8	NC	NC
0	SW	Internal Power MOSFET Drain.

BLOCK DIAGRAM

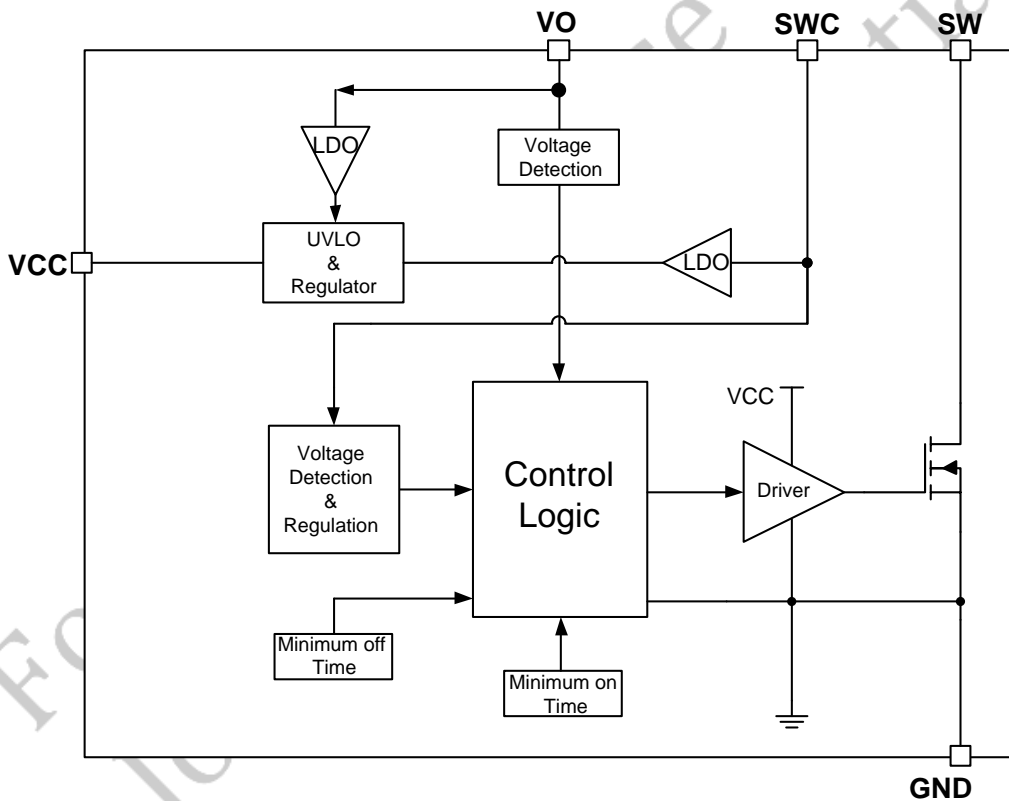

FUNCTIONAL DESCRIPTION

Operation

JW77156D is a synchronous rectifier which combined with internal MOSFET can replace the Schottky Barrier Diode. It supports all operations, such as DCM, CrCM, (Quasi-Resonant) and CCM when adopted in flyback converter.

Startup

During the startup period, when the VCC is lower than startup voltage, the external MOSFET is turned off. The current flows though body diode before the VCC reaches to the startup voltage $V_{cc_startup}$.

Under-Voltage Lockout (UVLO)

When the VCC is below UVLO threshold, the external MOSFET is turned off and pulled low internally. Once the VCC exceeds the startup voltage $V_{cc_startup}$, the parts is activated again.

LDO Charging Logic

JW77156D have two internal LDO to charge the VCC pin. When VO is lower than 4.35V, JW77156D can power itself through the internal LDO connected to SWC pin during the SR turn-off period, which means primary the primary side MOSFET is turned on and SWC presents a positive voltage. A capacitor between VCC and GND is required to store the energy and supply to IC during the SR turn-on period.

The other internal LDO is connected from VO to

VCC, it charges VCC pin when VO is higher than 4.55V.

Turn On Phase

When the synchronous MOEFET is conducting, current flows through the body diode of MOSFET, which generates a negative voltage V_{SW} across it. When V_{SW} is lower than V_{MOS_ON} , the part will pull the internal gate high to turn on the synchronous MOSFET after turn on delay time T_{DON} .

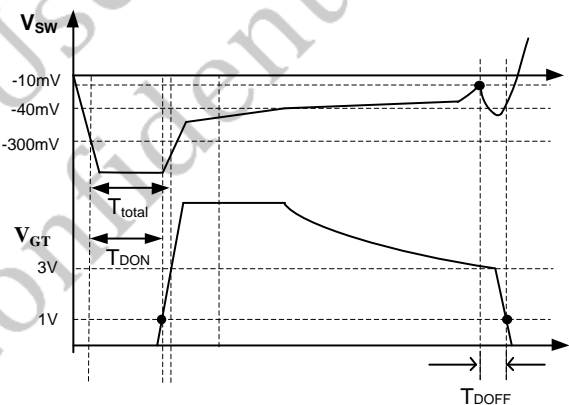

Figure-1 Turn on delay and turn off delay

Conducting Phase

When the synchronous MOSFET is turn on, the drain source voltage V_{sw} it is determined by its on resistance and the current through it. The part adjusts the gate voltage and regulates the V_{sw} to a internal threshold (typical -40mV) after the synchronous MOSFET turn on. When the V_{sw} is lower than -40mV, the gate keep its maximum voltage. And the synchronous MOSFET is fully on.

The control circuit contains a minimum on time function. The V_{sw} voltage may have a parasitic ring when the synchronous MOSFET turns on. So a minimum on time (MOT) is very important

to avoid the MOSFET turn off threshold is false triggered. During the minimum time, the gate can still be turned off if V_{SW} touches a positive threshold value, +150mV.

Turn Off Phase

After synchronous MOSFET conducting, once the voltage V_{SW} touches the MOSFET turn off threshold (-10mV), the internal gate is pulled to low after a turn off delay time T_{DOFF} . A 700nS blanking time is necessary to avoid error trigger.

Minimum On-time (MOT)

MOT stands for the minimum on time of synchronous MOSFET. For JW77156D, MOT is about 1.3uS.

Output Voltage Detection

The JW77156D has output voltage detection function via VO pin. To avoid the gate error turn on during starting-up period, the whole SR control logic is disabled when the VO voltage is lower than 2.1V. VCC is charged from VO pin when VO is higher than 4.55V to save power loss caused by the LDO when charging from SWC pin to VCC pin.

For 和创绿能 Use Only
JoulWatt Confidential

TAPE AND REEL INFORMATION

Reel UNIT: mm

SYMBOL	MILLIMETER		
	MIN	NOM	MAX
A	1.05	1.15	1.25
A1	0	0.05	0.15
A2	0.95	1.10	1.20
b	0.20	0.40	0.60
c	0.05	—	0.21
D	2.72	2.92	3.12
E	2.60	2.80	3.00
E1	1.40	1.60	1.80
e	0.95 (BSC)		
L	0.30	0.45	0.60
θ	0°	—	8°

Package	Diameter Φ	Thickness W1	Width W2	W4
ESOP8	330±2	17.6±2	12.4±2	100±2

Carrier Tape

UNIT: mm

QUADRANT ASSIGNMENTS FOR PIN 1 ORIENTATION IN TAPAE

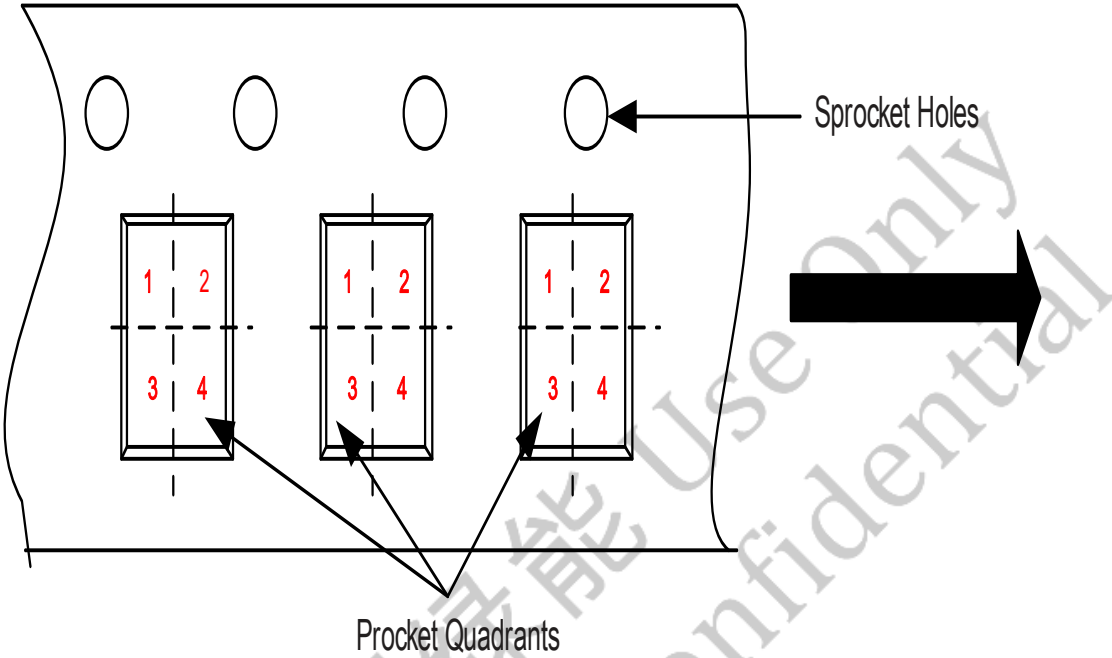

Package	Tape dimensions (mm)											
	P0	P2	P1	A0	B0	W	T	K0	Φ1	Φ2	E	F
ESOP8	4.0±0.1	2.0±0.1	8.0±0.1	6.40±0.3	5.35±0.3	12.0±0.3	0.25±0.2	2.00±0.2	1.50min	1.50min	1.75±0.1	5.50±0.10

PACKAGE OUTLINE

ESOP8 UNIT: mm

Symbol	MILLIMETER		
	MIN	NOM	MAX
A	1.30	1.50	1.70
A1	0.10	0.15	0.20
A2	1.35	1.42	1.55
A3	0.66	0.67	0.68
c	0.170	0.203	0.250
E	3.80	3.90	4.00
E1	5.80	6.00	6.20
L	0.45	0.60	0.75
b	0.33	0.40	0.51
D	4.80	4.90	5.00
e	1.27BSC		
θ	1°	3°	5°

L/F Szie (mil)	Symbol	MILLIMETER		
		MIN	NOM	MAX
90*90	D1	2.034	2.184	2.334
	E2	2.034	2.184	2.334
95*130	D1	2.953	3.103	3.253
	E2	2.063	2.213	2.363

QUADRANT ASSIGNMENTS FOR PIN 1 ORIENTATION IN TAPAE

Package Type	Pin1 Quadrant
ESOP8	1

IMPORTANT NOTICE

- Joulwatt Technology Co.,Ltd reserves the right to make modifications, enhancements, improvements, corrections or other changes without further notice to this document and any product described herein.
- Any unauthorized redistribution or copy of this document for any purpose is strictly forbidden.
- Joulwatt Technology Co.,Ltd does not warrant or accept any liability whatsoever in respect of any products purchased through unauthorized sales channel.
- JOULWATT TECHNOLOGY CO.,LTD PROVIDES TECHNICAL AND RELIABILITY DATA (INCLUDING DATASHEETS), DESIGN RESOURCES (INCLUDING REFERENCE DESIGNS), APPLICATION OR OTHER DESIGN ADVICE, SAFETY INFORMATION AND OTHER RESOURCES, AND DISCLAIMS ALL WARRANTIES, EXPRESS AND IMPLIED, INCLUDING WITHOUT LIMITATION ANY IMPLIED WARRANTIES OF MERCHANTABILITY, FITNESS FOR A PARTICULAR PURPOSE OR NON-INFRINGEMENT OF THIRD PARTY INTELLECTUAL PROPERTY RIGHTS.

Copyright © 2023 JoulWatt

All rights are reserved by Joulwatt Technology Co.,Ltd